

12W Single/Dual USB Charger Adapter Emulator

FEATURES

- Support BC1.2 USB-IF certification
- 4.5V~5.5V Single Supply Operation.
- Automatic USB charger Identification Circuit.
- UC2633B/UC2634B Support Apple® Devices fast charging. (Apple® 2.4A mode)
- Support Samsung Galaxy Tab Devices fast Charging. (Samsung® 2.1A mode)
- Support BC1.2 & YD/T 1591-2009 Charging Spec. (DCP® 1.0A mode)
- Available in SOT23-6 Package.

APPLICATIONS

- Power Bank/Car Charger

- USB Wall Adapter
- Travel Charger

DESCRIPTION

The UC2633B/UC2634B is single/dual USB adapter emulators with automatic host charger identification circuitry for USB dedicated chargers.

The devices integrated automatic USB charger identification circuit allow mobile power supply, In-Car charger, USB wall adapters, travel chargers, and other dedicated chargers to identify themselves as a USB dedicated charger to USB devices, like Apple charger to Apple products, Samsung charger to Samsung Galaxy Tab & Smart Phone, and BC1.2 charger to HTC, SONY, LG, BlackBerry, Lenovo, Coolpad, ZTE, Huawei and other legacy D+/D- short detection devices.

PACKAGE AND APPLICATION

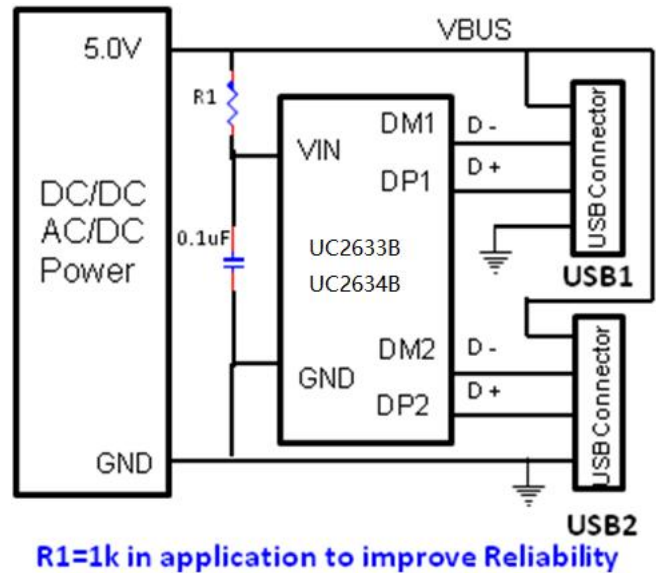
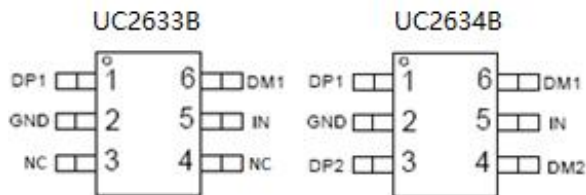

PART NO. TABLE

Part No.	Dual/Single	Apple 12W	Apple 10W	Apple 5W	SS 10W	DCP 5W
UC2633B	Single	Support			Support	Support
UC2634B	Dual	Support			Support	Support

12W Single/Dual USB Charger Adapter Emulator

ORDERING INFORMATION

Part Number	Package Type	Package Qty	Op Temp(°C)
UC2633B	SOT23-6	3000	-40~85
UC2634B	SOT23-6	3000	-40~85

MARK INFORMATION

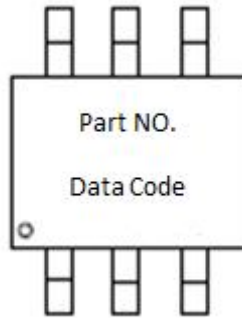

ABSOLUTE MAXIMUM RATINGS (1)

Over recommended operating free-air temperature range (unless otherwise noted)

PARAMETER		MIN	MAX	UNIT
supply voltage range	IN	-0.3	6	V
Input voltage range	DP1,DM1,DP2,DM2	-0.3	5.8	
Continuous output sink current	DP1,DP2 input current, DM1,DM2 input current		35	mA
Continuous output source current	DP1,DP2 output current, DM1,DM2 output current		35	
ESD rating, Human Body Model (HBM)	IN		8	kV
	DP1,DP2,DM1,DM2		8	
Operating Junction Temperature	T _J	-40	125	°C
Storage Temperature Range	T _{stg}	-65	150	

(1) Stresses beyond those listed under Absolute Maximum Ratings may cause permanent damage to the device. These are stress ratings only, and functional operation of the device at these or any other conditions beyond those indicated under Recommended Operating Conditions is not implied. Exposure to absolute-maximum-rated conditions for extended periods may affect device reliability.

12W Single/Dual USB Charger Adapter Emulator

THERMAL CHARACTERISTICS

over operating free-air temperature range (unless otherwise noted)

THERMAL METRIC			UNIT
θ_{JA}	Package thermal impedance ⁽¹⁾	180	°C/W

(1) The package thermal impedance is calculated in accordance with JESD 51-7.

RECOMMENDED OPERATING CONDITIONS

PARAMETER		MIN	MAX	UNIT
V_{IN}	Input voltage of IN	4.5	5.5	V
$V_{DP1/DP2}$	D+ data line input voltage		5.5	
$V_{DM1/DM2}$	D- data line input voltage		5.5	
$I_{DP1/DP2}$	Continuous sink/source current		±10	mA
$I_{DM1/DM2}$	Continuous sink/source current		±10	
T_J	Operating Junction Temperature	-40	125	°C

12W Single/Dual USB Charger Adapter Emulator

PINOUT

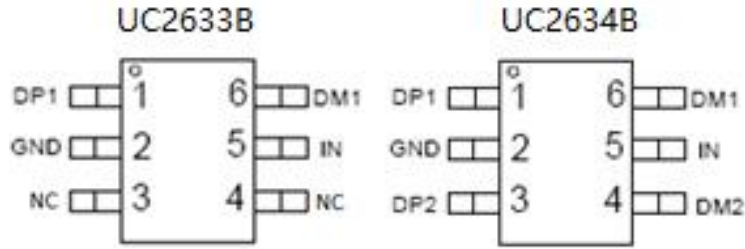

PIN FUNCTIONS

NO.	NAME	TYPE ⁽¹⁾	DESCRIPTION
1	DP1	O/I	DP date line to connector, output for hand-shake voltage to portable equipment, high impedance while disabled
2	GND	G	Ground connection
3	NC (UC2633B)	NC	No Connection
	DP2 (UC2634B)	O/I	DP date line to connector, output for hand-shake voltage to portable equipment, high impedance while disabled
4	NC (UC2633B)	NC	No Connection
	DM2 (UC2634B)	O/I	DM data line to connector, input for hand-shake voltage from portable equipment high impedance while disabled
5	IN	P/I	Power supply/Input voltage connected to Power Switch; connect a 1 μF or greater ceramic capacitor from IN to GND as close to the IC as possible
6	DM1	O/I	DM data line to connector, input for hand-shake voltage from portable equipment high impedance while disabled

(1) G = Ground, I = Input, O = Output, P = Power

12W Single/Dual USB Charger Adapter Emulator

ELECTRICAL CHARACTERISTICS

Conditions are $-40^{\circ}\text{C} \leq (T_J = T_A) \leq 125^{\circ}\text{C}$ and $4.5\text{ V} \leq V_{IN} \leq 5.5\text{ V}$ unless otherwise noted. Typical value is at 25°C . All voltages are with respect to GND unless otherwise noted.

PARAMETER		TEST CONDITIONS	MIN	TYP	MAX	UNIT
UNDERVOLTAGE LOCKOUT						
V_{UVLO}	IN rising UVLO threshold voltage		3.9	4.1	4.3	V
	Hysteresis			100		mV
SUPPLY CURRENT						
I_{IN}	IN supply current			160	300	μA
BC 1.2 DCP MODE (SHORT)						
R_{DPM_SHORT}	DP / DM shorting resistance	$V_{D+} = 0.8\text{V}, I_{D+} = 1\text{mA}$,		125	200	Ω
R_{DCHG_SHORT}	Resistors connected DP /DM to GND after hand-shaking	$V_{D+} = 0.8\text{V}$		200	400	$\text{k}\Omega$
$V_{DPL_TH_DETACH}$	DP low threshold while detaching BC1.2 devices		310	330	350	mV
$V_{DPL_TH_DETACH_HYS}$	hysteresis			50		mV
IPAD MODE(UC2633B/UC2634B)						
V_{DP_IPAD}	DP1/DP2 output voltage	$V_{IN}=5.0\text{V}$	2.55	2.7	2.85	V
V_{DM_IPAD}	DM1/DM2 output voltage	$V_{IN}=5.0\text{V}$	2.55	2.7	2.85	V
R_{DP_IPAD}	DP1/DP2 output impedance	$V_{IN}=5.0\text{V}, I_{D+} = -5\mu\text{A}$	20	30	40	$\text{k}\Omega$
R_{DM_IPAD}	DM1/DM2 output impedance	$V_{IN}=5.0\text{V}, I_{D-} = -5\mu\text{A}$	20	30	40	$\text{k}\Omega$
Galaxy Tab MODE						
V_{DP_GAL}	DP1/DP2 output voltage	$V_{IN}=5.0\text{V}$	1.1	1.2	1.3	V
V_{DM_GAL}	DM1/DM2 output voltage	$V_{IN}=5.0\text{V}$	1.1	1.2	1.3	
R_{DP_GAL}	DP1/DP2 output impedance	$V_{IN}=5.0\text{V}, I_{D+} = -5\mu\text{A}$	80	105	130	$\text{k}\Omega$
R_{DM_GAL}	DM1/DM2 output impedance	$V_{IN}=5.0\text{V}, I_{D-} = -5\mu\text{A}$	80	105	130	

12W Single/Dual USB Charger Adapter Emulator

FUNCTIONAL BLOCK DIAGRAM

UC2633B Block Diagram

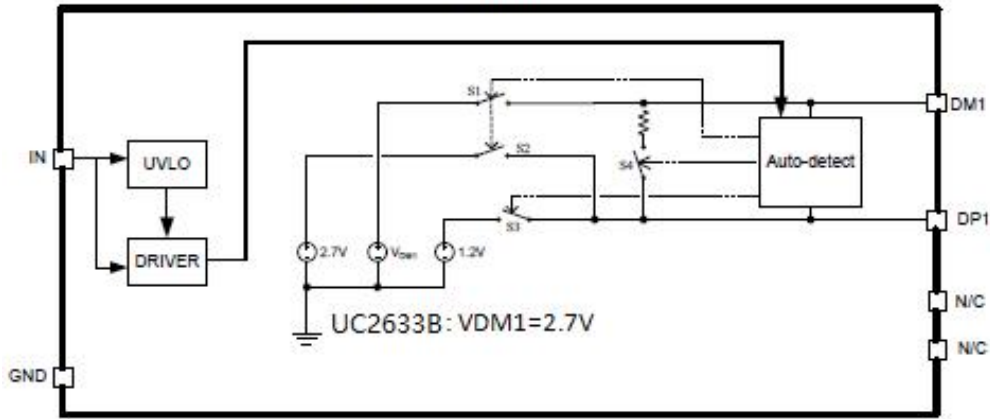

UC2634B Block Diagram

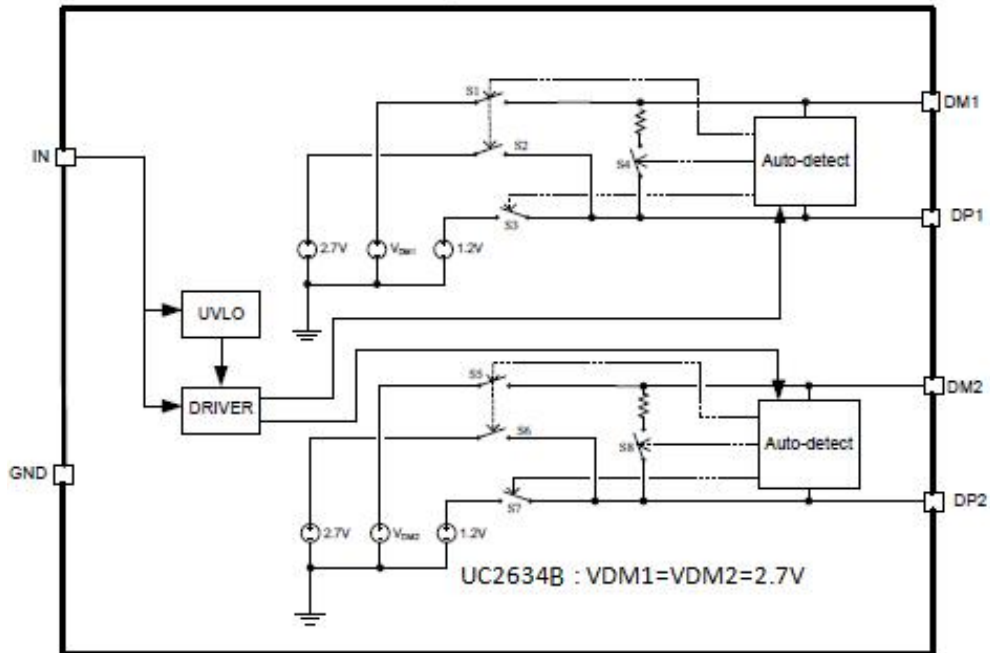

12W Single/Dual USB Charger Adapter Emulator

PACKAGE INFORMATION

SOT23-6

