

Single USB Charger Adapter Emulator

DESCRIPTION

The UC2635 is USB adapter emulators with automatic host charger identification circuitry for USB dedicated chargers.

The devices integrated automatic USB charger identification circuit allow mobile power supply, In-Car charger, USB wall adapters, travel chargers, and other dedicated chargers to identify themselves as a USB dedicated charger to USB devices, like Apple charger to Apple products, Samsung charger to Samsung Galaxy Tab & Phone, and BC1.2 charger to HTC, SONY, LG, BlackBerry, Lenovo, Coolpad, ZTE, Huawei and other legacy D+/D- short detection devices.

The devices feature a control input that allows for charger mode selection. The UC2635 supports both Apple 2.1A, Galaxy 2.0A and USB BC1.2 compliant devices in SEL Floating or SEL Pull-High and Apple 2.1A, Galaxy 2.0A and USB BC1.2 compliant devices in SEL Pull Down.

FEATURES

- 4.5V~5.5V Single Supply Operation.
- SEL Pin Control Charger Mode.
- Automatic USB charger Identification Circuit.
- Support Apple® Devices fast charging. (Apple® 2.1A / 2.4A mode)
- Support Samsung Galaxy Tab Devices fast Charging.
- Support BC1.2 & YD/T 1591-2009 Charging Spec.
- Available in SOT23-5 Package.

APPLICATIONS

- Mobile Power Supply
- In-Car Charger
- USB Wall Adapter
- Travel Charger

UC2635 SOT23-5 PACKAGE and SIMPLIFIED APPLICATION

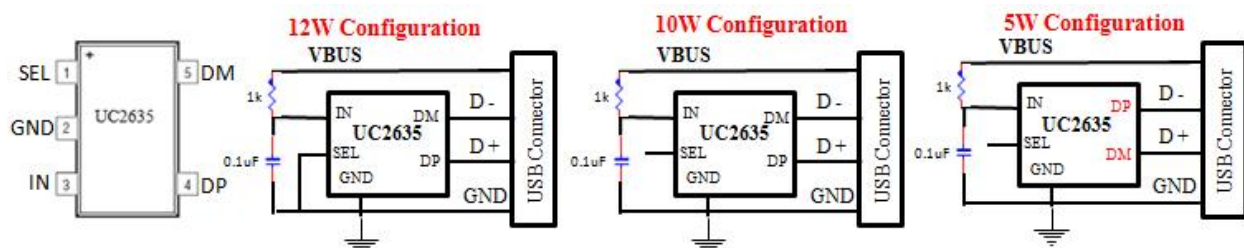

ORDERING INFORMATION

Part Number	Package Type	Package Qty	Op Temp(°C)
UC2635	SOT23-5	3000	-40~85

Single USB Charger Adapter Emulator

ABSOLUTE MAXIMUM RATINGS ⁽¹⁾

Over recommended operating free-air temperature range (unless otherwise noted)

PARAMETER		MIN	MAX	UNIT
supply voltage range	IN	-0.3	6	V
Input voltage range	DP,DM	-0.3	5.8	
Continuous output sink current	DP input current, DM input current		35	mA
Continuous output source current	DP output current, DM output current		35	
ESD rating, Human Body Model (HBM)	IN		5.5	kV
	DP, DM		8	
ESD rating, Charging Device Model (CDM)			500	V
Operating Junction Temperature	T _J	-40	125	°C
Storage Temperature Range	T _{stg}	-65	150	

(1) Stresses beyond those listed under Absolute Maximum Ratings may cause permanent damage to the device. These are stress ratings only, and functional operation of the device at these or any other conditions beyond those indicated under Recommended Operating Conditions is not implied. Exposure to absolute-maximum-rated conditions for extended periods may affect device reliability.

THERMAL CHARACTERISTICS

over operating free-air temperature range (unless otherwise noted)

THERMAL METRIC			UNIT
θ_{JA}	Package thermal impedance ⁽¹⁾	180	°C/W

(1) The package thermal impedance is calculated in accordance with JESD 51-7.

RECOMMENDED OPERATING CONDITIONS

PARAMETER		MIN	MAX	UNIT
V _{IN}	Input voltage of IN	4.5	5.5	V
V _{DP/DM}	DP/DM data line input voltage		5.5	
I _{DP/DM}	Continuous sink/source current		±10	mA
T _J	Operating Junction Temperature	-40	125	°C

Single USB Charger Adapter Emulator

PINOUT

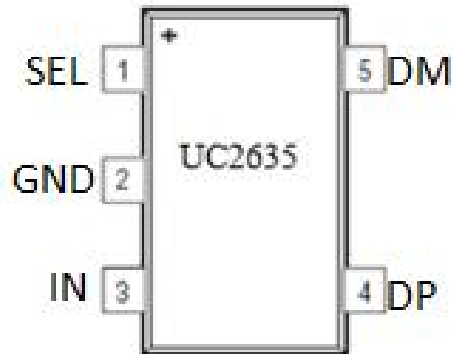

PIN FUNCTIONS

NO.	NAME	TYPE ⁽¹⁾	DESCRIPTION
1	SEL	I	Mode selection pin. SEL = FLOAT or "1" is 10W mode, SEL = "0" is 12W mode.
2	GND	G	Ground connection
3	IN	P/I	Power supply/Input voltage connected to Power Switch; connect a 1 μ F or greater ceramic capacitor from IN to GND as close to the IC as possible
4	DP	O/I	DP data line to connector, output for hand-shake voltage to portable equipment, high impedance while disabled
5	DM	O/I	DM data line to connector, input for hand-shake voltage from portable equipment high impedance while disabled

(1) G = Ground, I = Input, O = Output, P = Power

MARK INFORMATION

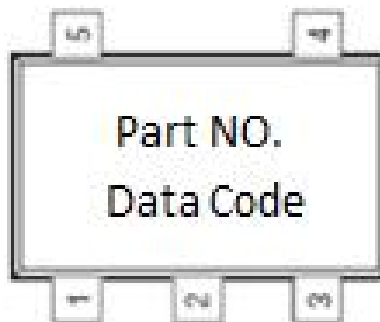

Single USB Charger Adapter Emulator

ELECTRICAL CHARACTERISTICS

Conditions are $-40^{\circ}\text{C} \leq (T_j=T_A) \leq 125^{\circ}\text{C}$ and $4.5\text{ V} \leq V_{\text{IN}} \leq 5.5\text{ V}$ unless otherwise noted. Typical value is at 25°C . All voltages are with respect to GND unless otherwise noted.

PARAMETER	TEST CONDITIONS	MIN	TYP	MAX	UNIT	
UNDERVOLTAGE LOCKOUT						
V_{UVLO}	IN rising UVLO threshold voltage	3.9	4.1	4.3	V	
	Hysteresis		100		mV	
SUPPLY CURRENT						
I_{IN}	IN supply current		160	250	μA	
BC 1.2 DCP MODE (SHORT)						
$R_{\text{DPM_SHORT}}$	DP / DM shorting resistance		125	200	Ω	
$R_{\text{DCHG_SHORT}}$	Resistors connected DP /DM to GND after hand-shaking		200	400	k Ω	
$V_{\text{DPL_TH_DETACH}}$	DP low threshold while detaching BC1.2 devices	310	330	350	mV	
$V_{\text{DPL_TH_DETACH_HYS}}$	hysteresis		50		mV	
IPAD MODE 2.1A Mode (SEL=1 or Floating)						
$V_{\text{DP_IPAD}}$	DP output voltage	2.5	2.7	2.9	V	
$V_{\text{DM_IPAD}}$	DM output voltage	1.8	2.0	2.2	V	
$R_{\text{DP_IPAD}}$	DP output impedance	$I_{\text{DP}} = -5\mu\text{A}$	20	30	40	k Ω
$R_{\text{DM_IPAD}}$	DM output impedance	$I_{\text{DM}} = -5\mu\text{A}$	20	30	40	k Ω
IPAD MODE 2.4A Mode (SEL=0)						
$V_{\text{DP_IPAD}}$	DP output voltage	2.5	2.7	2.9	V	
$V_{\text{DM_IPAD}}$	DM output voltage	2.5	2.7	2.9	V	
$R_{\text{DP_IPAD}}$	DP output impedance	$I_{\text{DP}} = -5\mu\text{A}$	20	30	40	k Ω
$R_{\text{DM_IPAD}}$	DM output impedance	$I_{\text{DM}} = -5\mu\text{A}$	20	30	40	k Ω
Galaxy Tab MODE						
$V_{\text{DP_GAL}}$	DP output voltage	1.1	1.2	1.3	V	
$V_{\text{DM_GAL}}$	DM output voltage	1.1	1.2	1.3		
$R_{\text{DP_GAL}}$	DP output impedance	$I_{\text{DP}} = -5\mu\text{A}$	80	105	130	k Ω
$R_{\text{DM_GAL}}$	DM output impedance	$I_{\text{DM}} = -5\mu\text{A}$	80	105	130	

Single USB Charger Adapter Emulator

FUNCTIONAL BLOCK DIAGRAM

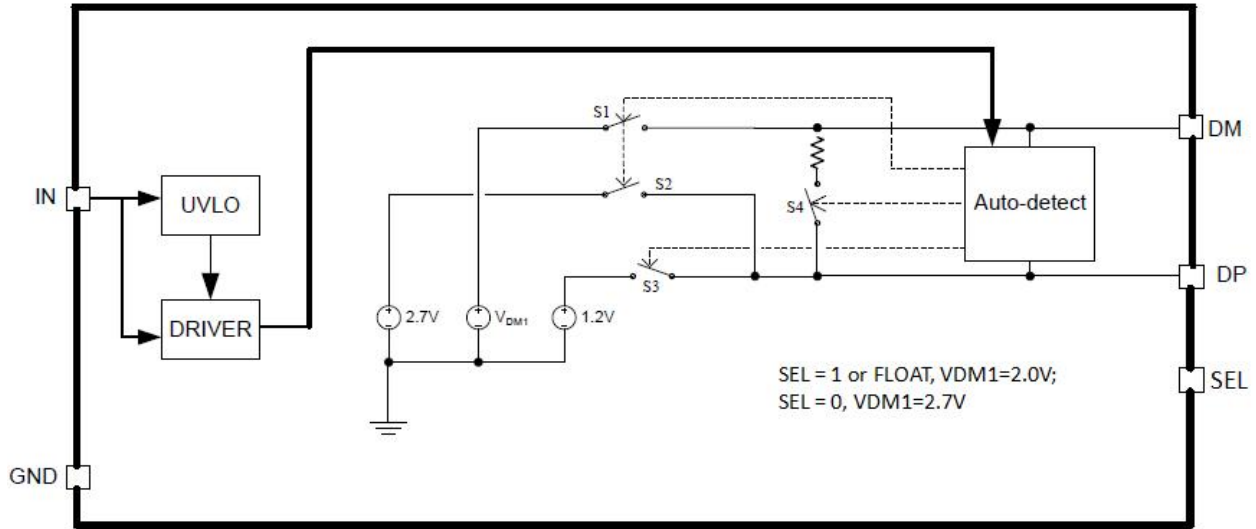

Single USB Charger Adapter Emulator

PACKAGE INFORMATION

SOT23-5

